



TIMKEN®

PRODUCTS + SERVICES
PORTFOLIO

+

+



MARKET

Every day, a spirit of innovation inspires ideas from Timken that contribute to a more efficient world. It motivates our world-class engineers and technologists to minimize the friction that limits productivity. And their tools include some of the most advanced technical resources on the planet.

Our full range of bearings, housed units, power transmission products and advanced services is hard at work in countless industries around the world. Designed for excellent performance, our portfolio helps your equipment run better – and helps boost your profitability.

Everything we say, everything we do is by design: to perpetually improve ourselves so we further strengthen those we serve. Everything we do aims to make each interaction with Timken better than the one before, more valuable than what was expected. Together, we are stronger, by design.

Stronger. By Design.



TABLE OF CONTENTS

PG 04-05	BEARINGS
PG 06-07	HOUSED UNITS
PG 08-09	POWER TRANSMISSION SOLUTIONS
PG 10-11	PRECISION BEARINGS
PG 12-13	REPAIR + SUPPORT
PG 14-15	ADVANCED SOLUTIONS
PG 16-17	KNOWLEDGE, TRAINING + TECHNICAL SUPPORT

BETTER BEARINGS, RELIABLE PERFORMANCE.

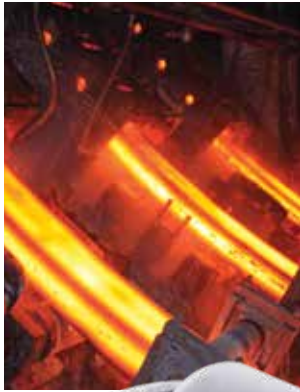

Putting advanced ideas in motion for more than a century has led to our best-in-class collection of bearings designed for every purpose, every application and every industry. If it moves, chances are we've played a role in the technology behind it. Made from high-performance steel, Timken bearings are better from the start and readily available to deliver the quality and performance that keep equipment moving.



TAPERED ROLLER BEARINGS

Not all bearings will face unforgiving conditions like huge payloads or high-contaminant environments. But when they do, Timken tapered roller bearings can handle the burden – with thousands of combinations in single-, double- and four-row configurations to manage both radial and thrust loads. Customized geometries, engineered surfaces and sealed versions can further enhance performance.

- » Increased power density means more performance in a smaller, lighter bearing
- » Rated among the highest in the industry for long life and low cost of ownership
- » True rolling motion allows for higher speeds with minimum roller skewing or skidding
- » Industry's broadest range of inch and metric sizes



SPHERICAL ROLLER BEARINGS

Misalignment. Contamination. High temperatures. Even extreme speeds or critical stresses can present extra challenges when managing high radial loads. Timken spherical roller bearings can handle it all, with innovations designed to extend bearing life and boost reliability.

- » Run at consistently lower temperatures than same-size competitive bearings for greater reliability
- » Multiple cage designs – including a wide range of both steel and brass options – help reduce stress at high shock loads or speeds and provide strong contaminant purge
- » Optimized internal geometries deliver the highest load and speed ratings in the industry

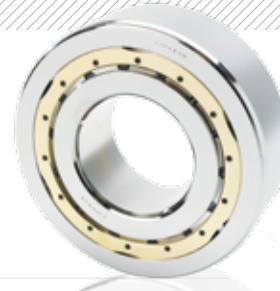

CYLINDRICAL ROLLER BEARINGS

Minimize drag. Reduce heat. And perform better, for longer, with less maintenance and downtime. These are the true tests of any bearing. Our expanded line of cylindrical roller bearings – including single-, double- and multi-row versions and full complement designs – can help extend equipment life and reduce maintenance costs.

- » EMA high-performance series offers premium brass land-riding cages that help decrease operating temperatures
- » Improved mounting capabilities in the four-row line for metal mills help avoid roller/ring damage during roll change for increased uptime
- » ADAPT™ line combines cylindrical and spherical roller bearing designs into one easy-to-assemble, high-capacity configuration – ideal for applications with combined misalignment and axial displacement



THRUST BEARINGS

When axial loads are combined with high speeds, heavy loads or other challenging conditions, thrust bearings deliver optimum performance. Timken offers the range needed for most any application in both standard and custom designs.

- » Cylindrical thrust types are suitable for heavy loads at moderate speeds
- » Spherical thrust types achieve a high thrust capacity with low friction and continuous roller alignment – even if the shaft and housing become misaligned during operation
- » Tapered thrust types are engineered for true rolling motion, which offers increased bearing life and additional load-bearing capacity
- » Ball thrust types suit high-speed applications and light loads



BALL BEARINGS

From electric motors to agricultural implements to food processing equipment, Timken ball bearings are engineered to perform in a wide range of applications and conditions.

- » Radial ball bearings tolerate relatively high-speed operation under various load conditions
- » Angular contact ball bearing designs include contact angles that support both radial and axial loads

PROTECTION IN HARSH ENVIRONMENTS.



Maintaining critical uptime can require more durable, heavy-duty components capable of protecting spherical, tapered and ball bearings in debris-filled, contaminated or high-moisture environments. Timken has engineered a lineup of housed units – one of the broadest available – to meet these various demands and offer the ideal level of bearing protection.

SNT/SAF PLUMMER (PILLOW) BLOCK HOUSED UNITS

Customizable design, interchangeable components and reliable spherical roller bearings deliver the heavy-duty performance that helps protect equipment and improve uptime in the harshest environments.

- » Variety of sealing options keep grease in and contamination out
- » Easily convert from fixed to float configurations in the field
- » Easy-to-remove cap for inspections, replacement and maintenance





SPHERICAL ROLLER BEARING SOLID BLOCK HOUSED UNITS

Cast steel housings with high-performance spherical roller bearings deliver outstanding durability in extreme conditions, including severe shock loads and vibration.

- » Multiple sealing options provide protection from contaminants in the harshest environments
- » Can be mounted and aligned in 15 minutes with a variety of available shaft-locking mechanisms
- » Easily convert from fixed to float configurations in the field



TYPE E TAPERED ROLLER BEARING HOUSED UNITS

A new standard in performance, Type E tapered roller bearing housed units are ideal for fixed positions and can withstand the most demanding conditions with less downtime and maintenance.

- » Seal provides industry-leading protection against contamination
- » Optimized internal geometries offer the highest dynamic load ratings in the industry for improved bearing life and performance



BALL BEARING HOUSED UNITS

Timken has delivered innovations that offer advanced performance, including wide inner ring bearing and ball bearing housed units. Easy installation, multi-seal design and multiple housing styles help ball bearing housed units support a wide range of demanding applications and conditions.

- » Provide advanced protection against contaminants in a robust, compact unit
- » Withstand static misalignment of +/- 3 degrees
- » Effective grease retention and reduced debris and moisture ingress improve performance

MAXIMUM EQUIPMENT PRODUCTIVITY.



A leader in power transmission and other related products, Timken technology handles the extreme temperatures and high contamination levels that affect equipment and productivity levels. As your total solutions provider, Timken offers a wide variety of products tailored to your needs – and the expertise to know which of those can enhance performance and longevity in various applications. With everything from seals to couplings, chain and lubrication, Timken has what it takes to help increase uptime, lower costs and keep industry moving forward.

COUPLINGS

Designed for high and low torques, and high and low speeds, Quick-Flex® couplings have the strength to handle tough challenges with little or no maintenance. Easy to install and requiring no lubrication, their life spans match those of rotating equipment to help keep the overall cost of ownership low.

- » Transmit the same or more torque than a gear, grid or other elastomeric coupling with similar dimensions
- » Replace coupling insert without moving hubs – maintenance takes minutes instead of hours
- » Sized to fit virtually all needs – with multiple hub and shaft combinations for easy mounting





SEALS

The ability to retain lubrication and block contaminants is critical to optimal bearing and system performance. Our complete line of industrial sealing solutions includes a variety of types and material options that provide resistance to extreme temperatures, pressure, debris and most chemicals.

- » Contact and non-contact designs suit any application – with excellent sealing capability
- » Durable materials can extend seal life and minimize maintenance
- » Secondary seals, covers and endcaps provide extra protection in harsher environments



CHAIN

Manufactured to meet or exceed ANSI standards, Timken chain performs. Our precision roller chain, attachment chain and engineered chain products excel in tough, high-performance applications and can be custom-manufactured to meet specific needs.

- » Wide-waisted link plates improve stress distribution for better performance
- » Precision hole quality increases working load and pin retention
- » Can withstand shock loads up to 50% of minimum ultimate tensile strength without premature elongation
- » Extensive range of stainless steel and coated options



LUBRICANTS AND LUBRICATION SYSTEMS

Serving industries around the world, Timken lubricants and lubrication systems are essential in maximizing performance, productivity and uptime. Leveraging our expertise in tribology and anti-friction bearings, we've developed lubricants – including 27 formulations of grease – that help ensure smooth operation. Our single- and multi-point lubricators, in addition to Interlube automated lubrication delivery systems, dispense precise amounts of grease, saving time and money over manual application.

- » High-temperature, anti-wear and water-resistant additives optimize consistent operation in even the most challenging environments
- » Multifaceted delivery systems serve virtually any application – from simple, single-point needs to multi-point or progressive systems where an automated process can maximize uptime and reduce maintenance costs
- » Patented chain lubrication systems inject oil where it's needed for reduced wear

EXTREME PRECISION, SUPERIOR ACCURACY.



Ultra-precision equipment requires more than a standard bearing can deliver. Our extensive range of precision bearing assemblies, designed for the critical tolerances demanded by precise applications, offers superior rotational accuracy, consistency and rigidity.

PRECISION MMV SERIES BALL BEARINGS

More and more, the world runs on ultra-precision equipment – everything from machine tooling to robotics to medical equipment. When faced with high-speed applications requiring both tight tolerances and super-fine surface finishes, Timken precision ball bearings are designed to deliver higher yields and lower costs.

- » Meet the highest industry standards – including ABEC 9/ISO P2 – in tolerance levels
- » High-performance cage designs allow for optimal operation at high speeds

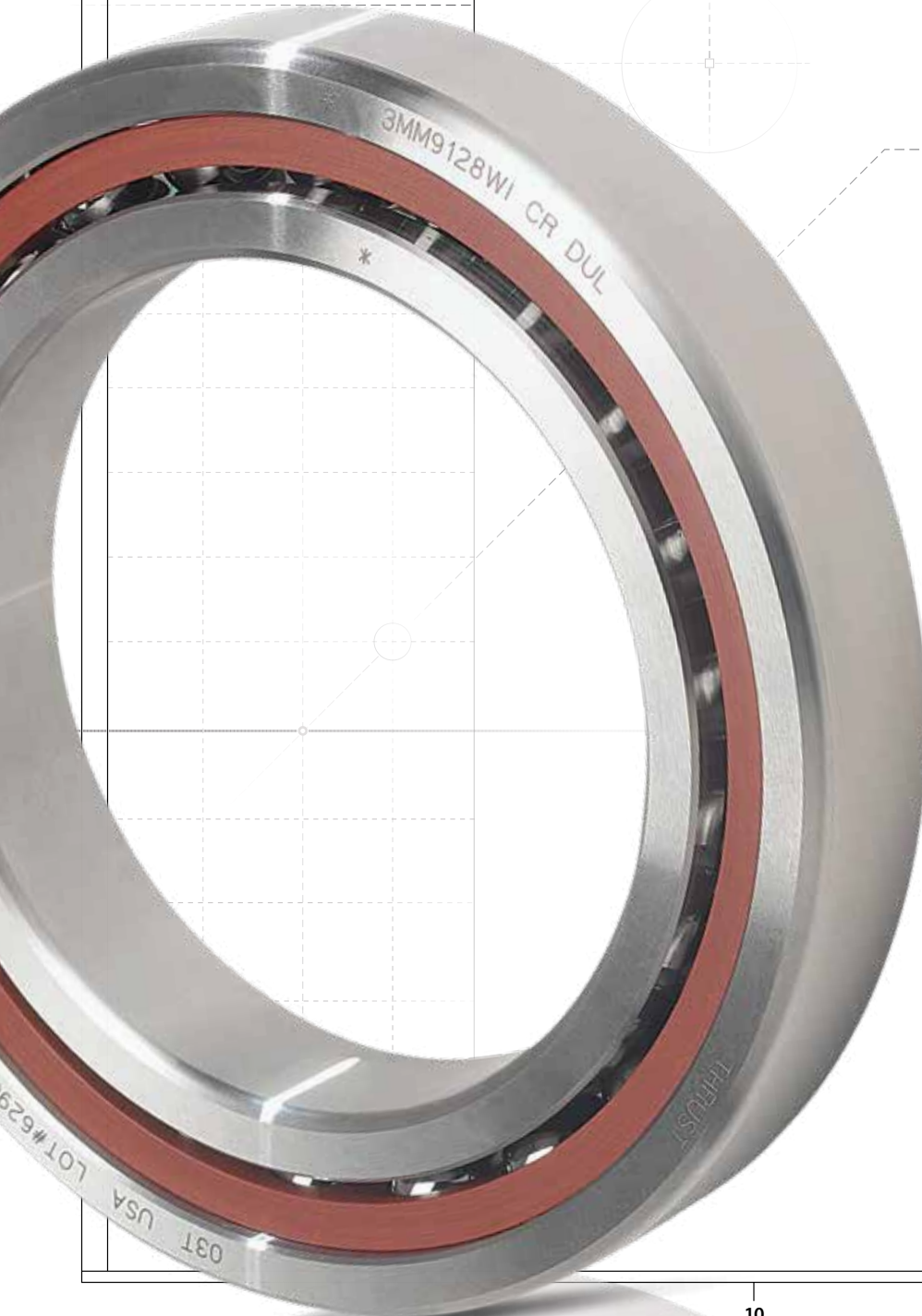



PRECISION BALL SCREW SUPPORT BEARINGS

Smooth and accurate positioning in motion control environments is possible. Our precision ball screw support bearings feature ABEC 9/ISO P2 axial running tolerances to reduce runout and can deliver the highest accuracy possible for tool positioning and repeatability. Integral low-torque contact seals are engineered to effectively exclude contaminants for reliable operation and extended service life.

- » Preload tolerances that are among the tightest in the industry
- » Cage design permits additional balls for higher load capacity
- » Flanged and nonflanged options simplify installation for both standard and rotating nut mountings



PRECISION CROSSED ROLLER BEARINGS

High rotational accuracy and rigidity in a space-saving bearing are attainable with precision crossed roller bearings. Our innovative design combines the compactness of a single-row bearing with the stability of a two-row bearing, saving on costs and materials. And the steep-angle tapered geometry results in a total effective bearing spread much greater than the width of the bearing itself.

- » Withstand high overturning moments
- » Ideal as a table bearing for machine tools, including vertical boring and grinding machines
- » Unique design delivers lower operating temperatures and high-speed performance



PRECISION TAPERED ROLLER BEARINGS

Applications such as machine tool spindles, printing press rolls and profile cutters require a high level of both precision and rigidity. Our full line of precision tapered roller bearings is engineered for superior accuracy and control – every time.

- » Produced to meet the full range of precision application requirements in both inch and metric systems
- » Reduced tolerances on bore and outside diameter improve performance
- » High load-carrying capacity for enhanced fatigue life



PRECISION MV SERIES BALL BEARINGS

Our MV series offers effective control of machine tool spindles and other demanding applications, with precision up to 1 million dN.

- » Low vibration and heat generation for smooth operation and low noise
- » Tolerances and uniformity exceed industry standards for superior dimensional and running accuracy
- » Lightweight polymer cage reduces friction to run cooler

MORE THAN PRODUCTS.



To strengthen those we serve, our commitment extends beyond products. We also offer the support needed to help ensure maximum uptime, low operating costs and optimal equipment life. It's more than product. It's teamwork.



INDUSTRIAL SERVICES

Experience counts, and Timken has plenty of it when it comes to inspecting, repairing and upgrading gearboxes, electric motors and controls to OEM specs – regardless of manufacturer. Keeping industry in motion has been the driving force behind this dedicated service team, uniquely equipped with an expansive knowledge base, highly engineered equipment and superior problem-solving skills to supply and service the entire mechanical drive train system.



BEARING REMANUFACTURING

Buying new bearings can be costly. But our remanufacturing service can return bearings for heavy industrial, rail and aerospace applications – even other brands – to like-new condition, extending service life by up to three times, and saving up to 60% on the cost of replacement bearings.



MAINTENANCE TOOLS

Beyond making world-class bearings, we offer the precision tools to install, remove and maintain them in the easiest, safest manner possible. Applying our engineering know-how to the design of a variety of induction heaters, impact fitting tools, and hydraulic and mechanical pullers, Timken develops the tools needed to maximize productivity and uptime, including offering hands-on field training on their use and maintenance.



ON-SITE TECHNICAL SUPPORT

Our on-site services are designed to help boost uptime and equipment reliability with technicians expert in motor, gearbox and bearing field services. For example, our MILLTEC® operation manages steel mill roll shop operations to maximize uptime during roll changing, roll grinding, bearing overhaul and other maintenance procedures. That means improved roll shop efficiency, lower operating costs and more of your resources focused on what's important – producing high-quality product.

DRIVEN TO INNOVATE.



Uptime. Productivity. Safety. Reliability. Profitability. Timken devotes the time and investment needed to help achieve what its customers really need. From high-performance coatings to diagnostic tools to highly specialized bearing packages, our dedication to innovation delivers what customers need to be their best.

COATINGS AND ENGINEERED SURFACES

Our innovative selection of hard coatings and topographical modifications can be used individually or in combinations to help boost the performance of precision components in difficult applications. And for high-debris environments, enhanced performance in equipment with marginal lubrication and debris resistance helps improve reliability.





CONDITION MONITORING DEVICES

Powerful diagnostic tools from Timken are designed to detect potential bearing failure before it occurs. A variety of handheld devices and online options – including our ultra-accurate Online Intelligence System – let you monitor bearing condition, lubrication quality and machine vibration (either periodically or continuously) for increased productivity, safety and peace of mind.



ENCODERS AND SENSORS

From industrial, medical and robotic applications to off-highway and automotive products, including many of the most popular models out today, sensors are used to precisely control movement in rotary equipment. Our experience in magnetic encoded technology has resulted in patented and customized products – with tens of millions serving the marketplace. Designed to withstand high vibration, shock and operating temperatures up to 135° C (275° F), Timken products feature higher accuracy and reliability than traditional encoder solutions.



INTELLIGENT BEARINGS

When complex application requirements test the limits of typical bearings, Timken intelligent bearing solutions provide the capabilities needed to ensure optimum performance. Our Sheave Pac® bearing assemblies for the oil and gas industry offer superior sealing abilities that help keep the bearing lubricated for the entire duty cycle – essential for limiting the safety risks associated with regular maintenance climbs. And Sensor-Pac™, with its integral sensing system design, is the first automotive wheel-end bearing to deliver total traction control under any condition.



INTEGRATED BEARING ASSEMBLIES

Across industries, Timken engineers collaborate with customers to design, engineer and test a continuous stream of next-generation solutions. Our integrated bearing assemblies – some of the most innovative in the industry – are the result of this collaborative process, including the game-changing AP-2™ bearing, which reduces weight and carries heavier loads in rail applications. Sealed roll neck bearings, with their proprietary sealing solutions, reduce contamination ingress and extend bearing life to help the metals industry lower its cost-per-ton-rolled expense.

ADDED VALUE THROUGH EXPERTISE.



With 200 technology, manufacturing, sales and distribution facilities, our global network puts Timken expertise within easy reach of customers around the world. We've simplified ordering and logistics, making it easy to get products when and where you need them. We've also designed training to create problem solvers, and found ways – like remanufacturing – to deliver uncompromising value. Our highly skilled team is ready to solve challenges and ensure a continuous flow of products, services and solutions to meet any need.



TECHNICAL CAPABILITIES

We offer customers more than a century of experience in friction management and materials science. That expertise means cleaner, stronger materials and an ever-growing selection of high-performance products. Whether it's an engineered surface, advanced seal or customized lubricant, our application engineers excel at identifying and overcoming unique challenges. And our commitment to electronics solutions holds the promise of smarter, more efficient operations today and in the future.

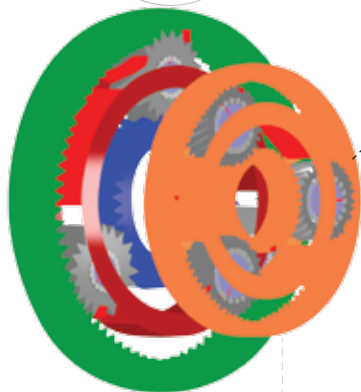

ADVANCED BEARING SYSTEM ANALYSIS

It's one of the most advanced bearing analysis tools available, with an unmatched, proprietary design that helps speed the system concept-to-design process with fewer test requirements. Our Syber Program analyzes bearing systems, helps optimize design and development, and predicts potential damage. And Timken customers also can perform base design analytics with their own version of this powerful software.



SERVICE ENGINEERING

Driven to keep equipment running efficiently, our service engineers thrive on overcoming challenges and seeking ways to prevent future problems. Tapping into data, testing and technical resources, these experts offer on-site problem solving, life cycle calculations, interface design options, and bearing inspections and evaluations to uncover new paths to greater efficiency and productivity.



ONLINE SERVICES

With our online services, purchasers can check product availability, place orders and track order status – 24/7 – while enjoying the benefits of Timken customer service, integrated logistics and global distribution network. For engineers, technical information – including CAD drawings, product selection tools, bearing life calculators and dimensional tolerances – is readily accessible via www.timken.com, making most jobs easier.



TRAINING AND CERTIFICATION

Passing along more than a century of knowledge, our field service engineering network provides on-site training, end-user maintenance seminars and bearing certification programs to help in selecting bearings and optimizing system performance. Our experienced engineers will tailor training to specific needs – from teaching the basics of bearings and proper installation to sharing time-tested practices and the latest technology. And our certification programs help maintenance shops gain efficiencies and improve performance.

Stronger. By Design.

As our customers continue to expand their possibilities regionally and across the globe, we remain a constant collaborator in that success – providing the products, tools and expertise needed to find better answers to increasingly complex problems. Through our focus, precision and passion for details, we produce results of lasting value for you.

No matter what challenge you face, call on the team at Timken to help you overcome the toughest problems. Together, we can help you succeed.

Together, we are stronger, by design.

The word "TIMKEN" is written in a bold, orange, sans-serif font. The background of the entire page is dark grey with white geometric lines, including a vertical dashed line on the left, a horizontal solid line, and various curved and intersecting lines that create a technical or architectural feel. There are also small white circles at some of the line intersections.

TIMKEN

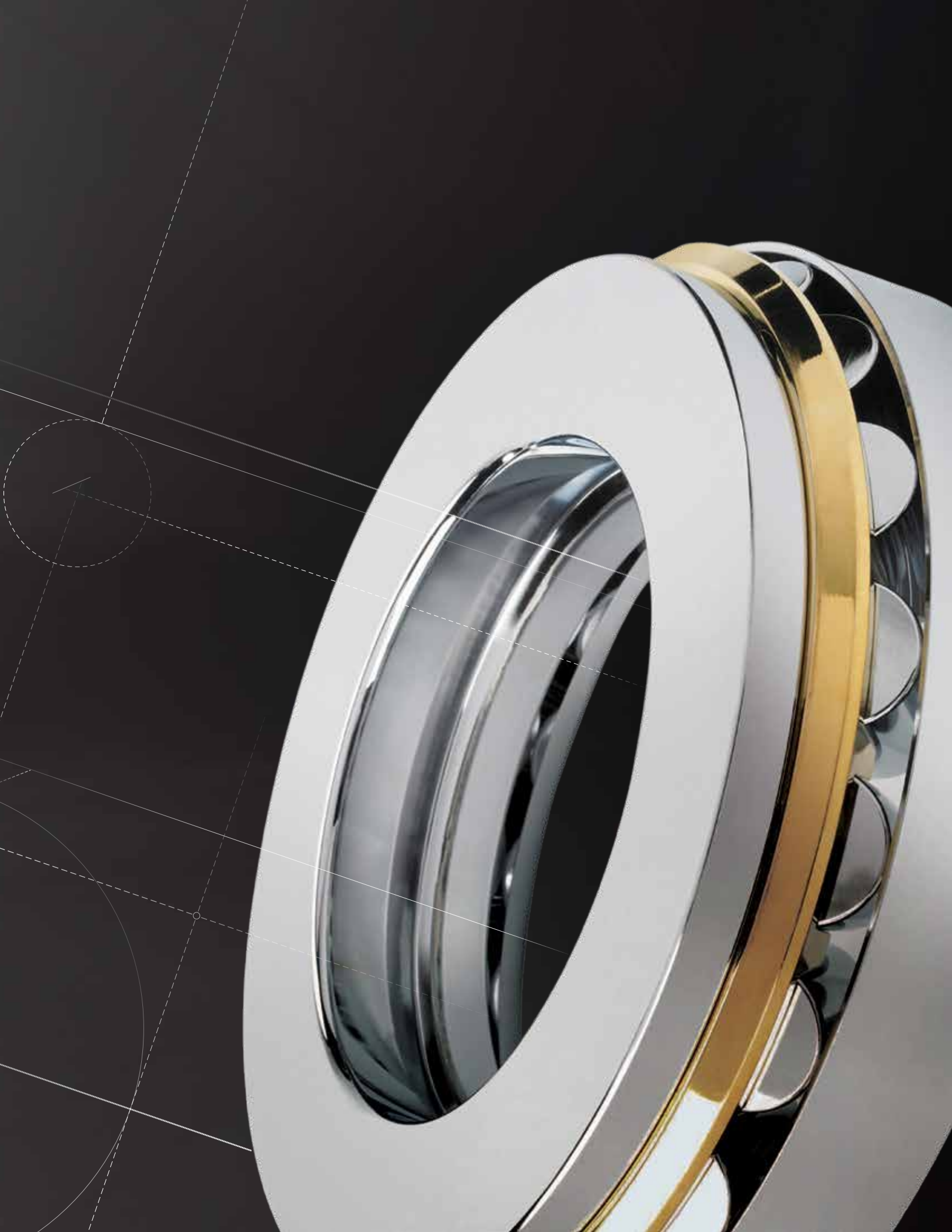

CALL ON THE LEADERS.

Our commitment to your success is our driving force. Let us help you overcome any challenge standing in the way.

For more information, visit us at www.timken.com.



TIMKEN®

- » BEARINGS
- » HOUSED UNITS
- » POWER TRANSMISSION SOLUTIONS
- » ADVANCED SOLUTIONS
- » REPAIR AND SUPPORT
- » KNOWLEDGE AND SERVICES

WWW.TIMKEN.COM

Stronger. By Design.

The Timken team applies their know-how to improve the reliability and performance of machinery in diverse markets worldwide. The company designs, makes and markets high-performance mechanical components, including bearings, gears, chain and related mechanical power transmission products and services.

20M 08-14:29 Order No. 10728
Timken® is a registered trademark of The Timken Company.
© 2014 The Timken Company
Printed in USA

